

The Physical Origin of Subtle Energies: The Principle Of Self-Organization Driving Living Systems

Richard L. Amoroso
Noetic Advanced Studies Institute
120 Village Square, MS 49
Orinda, CA 94563-2502 USA
Email: Cerebroscopic@mindspring.com

Elizabeth A. Rauscher
Tecnic Research Laboratory
3500 S. Tomahawk Road, Bldg. 188
Apache Junction, AZ 85219

Abstract: It has long been known that “subtle Energy” pervades the cosmos and every interstice of all forms of living systems. Until now there has never been a pragmatic scientific model of these energies that lends itself to rigorous empirical investigation. A self-organized cosmological model, called the Holographic Conscious Megaverse (HCM), has been developed wherein a teleological action naturally arises. This new complex self-organized action principle is synonymous with the unified field sought by physicists like Einstein; that in a conscious megaverse ‘pervades all space, gives life, is the light of the mind and the force that frames the heavens’. This action principle has broad application to fields of medicine and psychology.

Keywords: Biological mechanism, Complex systems, Energy medicine, Mind-body interaction, Self-organization, Subtle energies

1. The Fundamental Basis Of Self-Organized Living Systems (SOLS)

Generally unicellular prokaryotes (no true nucleus - division by fission not mitosis) are considered the most fundamental form of living system. Many researchers include viruses since they commandeer their hosts’ cellular machinery for replication; while others insist viruses are merely complex infective proteins. This controversy has continued over the last hundred years [64]. How could the question be answered if the nature of life is not well understood? New biological principles introduced suggest that the prion, the infectious protein responsible for transmissible spongiform encephalopathies (Mad Cow Disease) [67,68], qualifies as the most fundamental form of living system; but with a twist as we shall see. The prion appears to be the only known case of a purely mechanical life form; and therefore the only entity remaining in general concordance with the six-point definition of living systems put forth by Humberto Maturana and his colleagues in their original characterization of living organisms as a class of complex self-organized autopoietic systems in 1974 [1].

“What is the necessary and sufficient organization for a given system to be a *living unity*?” [1]. Maturana and his collaborators posed this question in their effort to formalize the general definition of a living system. They further stated that all other functions are secondary to the task of establishing and maintaining this unitary organization, defining this process as *autopoiesis* [1]. For review, a summary of Maturana’s description of an autopoietic living system follows through the next two sections:

Autopoiesis from the Greek ‘self-production’ is a fundamental expression of the basic complementarity of structure and phenomenology [2,3,4]. An autopoietic system is self-organized, complex, open, dissipative, self-referential, incursive, autocatalytic, hierarchical, far from equilibrium and autonomous. A system is autopoietic when its primary function is self-renewal through self-referential activity. This contrasts an allopoietic system like a robot deriving function from an external source. Stated another way autopoiesis is a network of production components participating recursively as a globally stable structure operationally separable from the background [1,2]. By metabolic work a living system is able to expel entropy (disorder) continually into its surrounding environment and thereby maintain the life process.

These properties of a complex self-organized living system operate in an ascending hierarchy:

- An autopoietic system is an open non-equilibrium system. If closed in equilibrium all processes die down.
- The processes are cyclical, recursive and incursive. (Incursion has recently been put forward as a fundamental physical principle [67,70])
- As a complex self-organized system, operations occur within multi-levels where higher levels contain all lower levels.
- Function – the primary function of the system is autopoiesis as defined above [1].
- Self-Organization in living systems is driven by a cosmologically based teleological action principle (A key addition to Maturana's principles formally introduced here).

While a teleological action principle, known as the life force or *élan vital*, has been discussed historically in theological, philosophical, and biological terms; this is the first time it has been introduced in a rigorous scientific manner open to empirical testing [71-2].

2. Summary Of Maturana's Six-Point Mechanistic Key For Determining Life

1. Does the entity have identifiable boundaries like a cell or body?
2. Does the entity have unique constitutive elements?
3. Is the entity a *mechanistic system* possessing properties satisfying certain relations for its interactions and transformations?
4. Do the components constituting the boundaries of the entity act through preferential relations and interactions between the components?
5. Are the components constituting the boundaries of the entity produced by interactions of the components either by transformation of previously produced components, or by transformations and/or coupling of non-component elements that enter the entity through its boundaries.
6. If all the other components of the entity are produced by the interaction of the components as in 5, the entity is an autopoietic entity in the space in which it exists [2].

3. Non-Autopoietic Entities Appearing To Satisfy Maturana's Conditions

Automata - Superficially automata [5] seem to obey Maturana's six points for autopoiesis, especially in terms of self-reproduction and autonomy; but they are readily disqualified for two salient reasons: Automata are generally nonphysical and cannot naturally escape or exist outside of the computer system they are programmed in.

Crystals - Crystalline structures conform to many of Maturana's six key requirements. The symmetry of the *unit cell* contains the geometric framework of the whole periodic structure, which is repeated in translations of the unit cell. So although a crystal has open self-organized boundary conditions, appears to be recursive and can reproduce; a crystal's main failing is that it remains mainly a chemical reaction because its 'unique constitutive elements' can only be reproduced and remain structure preserving under precise conditions of chemical reactivity. Crystals cannot expel entropy and have no self-renewal.

Ribosomes - Although partially comprised of components produced by the ribosome, as entities processes beyond those comprising their operation produce them; and their function is not completely self-referential [1]. Ribosomes have high-level metabolic properties but they are cellular organelles not unique unities in themselves.

Belousov-Zhabotinsky Reaction - A key aspect of a self-organized autopoietic system is its globally stable structure over an extended time. These are called *dissipative structures* because they maintain a continuous production of entropy, which is then continually dissipated. The best-known dissipative structure is the Belousov-Zhabotinsky Reaction produced by the oxidation of malonic acid by bromate where rotating concentric or spiral waves create interference patterns oscillating with a periodicity maintaining itself for many hours [2,6]. Although self-organized with environmental interplay, can this be more than a recursive chemical reaction?

Jantsch and Maturana both state that dissipative chemical reactions like the Belousov-Zhabotinsky reaction and the glycolytic cycle qualify as primitive autopoietic systems [1,2]. This is the first reason to question the finality of Maturana's conditions. Does this mean any of the entities in section 9.3 above should be accepted as living systems? Maturana's six-point key is not experimental; but a set of logical premises, and in that sense based arbitrarily on philosophical deduction. Even if these systems are considered autopoietic by the claim of definition, the thesis developed here is to not accept these types of entities as living-systems but to make a case for requiring additional

physical principles added to Maturana's mechanistic key to complete the requirements for properly defining a unique class of autopoietic systems qualifying as true Self-Organized Living-Systems (SOLS). Our conclusion is that Maturana's delineation of autopoiesis at best only defines the mechanistic components of self-organization. This has been a key problem hampering the comprehensive definition of life. Mechanism is so elegant and efficient (as it needs to be) that mechanism alone has been considered sufficient to describe life.

4. Mechanism In Biology As A Semi-Classical Limit

Autopoietic systems as defined by Maturana are a special class of *mechanistic system*. This has long been a challenging philosophical issue. It is generally considered an open question whether all biological process can be described completely in terms of the 'mechanics' of physics and chemistry. In the philosophy of biology *mechanism* is defined as the view that every event described as a biological event is the same as those exemplified in non-biological physical chemistry [7,8]. Beckner in a discussion of *mechanism* states:

"It is plausible to suppose that biology contains terms that could not be defined by reference to physics and chemistry, particularly if we count psychological phenomena as special cases of the biological, but perhaps even if we do not. Biological theory takes account of the circumstances of an event's occurrence in a way that the physical sciences do not. For example, it is a biological fact that lions hunt zebras. The biological mechanist ought to insist merely that everything that happens in a given case of zebra hunting is identical with a sequence of physicochemical events, not that the concept of hunting can be defined in physicochemical terms. It may be the case that *hunting* can be defined only in intentional language" [8].

This has left the final reductionist judgment for the standard model of biology an open question; and until recently this is where conceptual development had to remain. The philosophy of biological mechanism reviewed here is akin to philosophical naturalism that states: 'the natural world represents the whole of reality without requiring any additional teleological parameters'. This suggests that the current limits of scientific pragmatism provide sufficient explanation for all universal phenomena. Arguments on mechanism and naturalism have not been quite beaten to death. Let it suffice for the purposes here to postulate that additional scientific laws need to be introduced because 'lion hunting' as intentional action is not describable by the laws of physics and chemistry alone.

As argued above one cannot in good conscience label the Belousov-Zhabotinsky reaction [2,6] as a living system any more than one can logically allocate consciousness with reasonable definition to the bi-level state of a thermostat as has been done in Artificial Intelligence (AI) circles. However the sophistication of the mechanical properties of self-organization in autopoietic systems cannot be discounted. While this inherent complex order provides a highly efficient substrate for living systems to be built on, like a little finger applied to the helm of a megaton ship is able to steer it. We intend to show that mechanism alone provides an insufficient basis for the complete description of SOLS. A teleological action principle, inherent in the Holographic Conscious Multiverse (HCM) [9,10,78], acting in concert with mechanism is required for life, providing components of what cosmologists have recently called the holographic cosmological principle [73].

5. New Cosmology Helps Redefine Biology

The success of Gauge Theory in describing elementary particles and their interactions has led to the standard model of particle physics. Gauge Theory or *gauging* provides a way to simplify the transformation of the underlying symmetry used to represent the internal structure for measuring interactions in standard Einstein-Minkowski 3(4)D spacetime (often called the Einstein Gauge). But Gauge Theory is only an approximation suggesting it will be replaced by a more fundamental principle [74] like the geometric principle Einstein used in formulating General Relativity from the approximation of Newton's gravity. It is believed that a massive photon would violate local gauge conservation laws, which are one of the fundamental concepts of modern physics. This would not be true in a higher dimensional (HD) space [75] where the photon may acquire mass by what is called spontaneous symmetry breaking [74]. This simple explanation for preserving the gauge principle in the local 4D gauge model allows the photon to have mass in the HD global case. A massive photon m_γ is allowed to have an internal symmetry with which it may couple to Dirac's model of a covariant polarized vacuum [76] supporting the new HCM cosmology needed as the basis for the work here.

Another essential factor not addressed here is what is called the Dirac polarized covariant vacuum [90]. This spacetime vacuum is key to the premises of HCM cosmology because it supports an energy dependent spacetime metric, massive photons, 12D reality of M-Theory (Superstring Theory). Although still unpopular, growing evidence supports Dirac’s model [92,93]. The Dirac vacuum has also produced a large body of literature in a field called Extended Electromagnetism [91].

In the HCM context it is easier to state that Hubble discovered a cosmological redshift not an expansion of the universe, which becomes an invalid interpretation. Therefore no mandate exists necessitating a trace back to an initial singularity (Bigbang) [77-8]. The Bigbang has two main pillars. The possibility of photon mass negates the first (expansion of the universe); and the other the Cosmic Microwave Background Radiation (CMBR), to which it has been stated ‘no alternative has ever been shown’ [79]. This issue has recently been addressed by using Cavity-QED to describe blackbody radiation in spacetime cavities as an equilibrium condition between redshift as absorption and CMBR as emission [80].

Until the advent of Noetic cosmology [9-12,66,77-8] physical cosmologists have generally believed that spacetime could not be highly ordered and symmetric with an inherent periodicity where the future-past prepares the present as a chain of instantaneous continuous state ‘nows’ [9] as a 3(4)D virtual reality that is a temporal subspace of a higher 11(12)D eternal multiverse (See Figs. 1 & 2 below). Such spacetimes were considered nonphysical and thought to violate the causal principles of quantum theory [13]; but Cramer [85] in what he calls a Transaction has shown this not to be true.

The standardized Copenhagen interpretation describes the boundary between Newtonian Classical Mechanics and Quantum Mechanics (QM). Classical Mechanics is macroscopic and considered a highly predictable clockwork. At the microscopic level described by QM uncertainties arise and the outcome of measurement of a system’s dynamics is statistically based. Probability was put into the Schrödinger equation as a wave function. When a measurement is taken the wave function is said to collapse. Because of the inherent uncertainty principle only position or momentum, particle or wave properties could be measured precisely, never both simultaneously. De Broglie, Bohm and Vigier have developed an alternative interpretation called the Causal Stochastic Interpretation (CSI) of quantum theory [81]. In the CSI model the quantum wave function continually evolves without collapsing; and therefore with no restriction on measurement of complementary observables because of causal aspects of a guidance principle called the quantum potential. The domain described by the CSI Interpretation is the regime at the boundary between extended quantum theory and the unified noetic field.

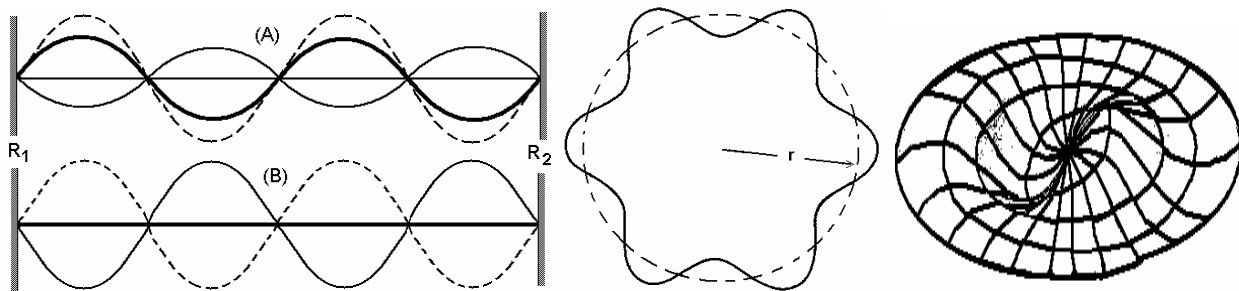

Figure 1. Examples of one, two and three-dimensional standing waves respectively. Standing waves are quantized energy or matter waves because of the restrictions imposed by boundary conditions like the clamps holding the ends of a violin string or the cavity of a wave guide that allow only a specific integral number of waves reflected back from the fixed ends in A) or circumference in B) & C) to produce a superposition of the waves. In the top part of 1A) the thin wave and dotted wave summate into the thick standing wave. In the bottom section the thin and dotted wave are 180° out of phase and superpose into the central zero amplitude thick wave. 1B) & C are 2 & 3D standing waves that could represent Bohr orbits in an atom. Following this metaphor up to 12D HCM cosmology postulates that reality itself is a form of complex standing wave.

In this regime SOLS or consciousness is able to violate quantum uncertainty because an extended form of CSI theory governs the description. From its inception quantum mechanics has been known to be both incomplete and unable to describe biological systems. Therefore how can biological mechanism which is a classical model offer a complete framework for describing living-systems since it is Newtonian!

Self-organization produces a form of *freedom*; and the degree of autonomy a system achieves in relation to its environment provides one way to loosely define *consciousness*. Jantsch says, “this autonomy appears as an expression of the fundamental interdependence of structure and function which is one of the most profound laws of dissipative self-organization” [2]. Drăgănescu further adds: “If a virus is alive it has a phenomenological subconscious, if not, it cannot have any form of consciousness, because there is no structural organization with sufficient complexity to process structural information significantly”[4]. This is similar to Maturana’s idea that the autonomy obtained by autopoiesis relegates a primitive form of consciousness (even to chemical dissipative structures), which he calls a *cognitive domain* in relation to the systems environment [3]. This is where we must draw a line in the sand and give a definitive description of the term *cognitive domain* that goes beyond Maturana’s and the current thinking on mechanism.

Consciousness, and not necessarily that with self-awareness, requires a sufficient number of degrees of freedom beyond those of an allopoietic mechanistic automaton. While one might reluctantly concede that the Belousov-Zhabotinsky reaction [2,6] is autopoietic because of Maturana’s original definition [1]; one cannot proscribe a cognitive domain with a structural-phenomenology capable of intentional action to such autocatalytic pattern-producing chemical reactions. How is this ultimately different than programmed automata? It seems that embracing biological mechanism leads one into the trap of ‘conscious thermostats’ used to support the Artificial Intelligence (AI) and cognitive view that algorithm alone is sufficient to describe the complexity of the human mind.

We believe the autocatalytic chemistry of the Belousov-Zhabotinsky reaction has a cyclical self-organization keeping the cycle in motion recursively by a chaotic component in the symmetry of the boundary conditions. This leads generally to a global stabilization of the reaction until a chance occurrence of an ordered ground state occurs. One could argue the reaction is the result of the inherent activity in the reactions so-called *cognitive domain* because it includes a self-referential multilevel hierarchy that maintains the cycle of the reactions self-production. This however at least violates Gödel’s incompleteness hypothesis: ‘a system cannot be completely described only in terms of itself’ [82,83]. One could carry this argument further to lend correspondence with Prigogine’s symmetry breaking factors in the thermodynamics of evolution [15,16]. But the driving force described by these arguments is not an intrinsic *intentional awareness*; it is more like the incongruent geometric symmetries driving the chain of unstable intermediaries in a radioactive decay series – automatic unraveling of atomic structure (a form of mechanism) continues as long as a stable ground state with boundary conditions that preserve the unity of the intermediate atom cannot yet be reached. These wonders instead display the elegance and efficiency of mechanism as a substrate for facilitating self-organization in living systems. Mechanism in this sense makes life “inexpensive”.

6. Living-Systems And Consciousness

Recall Jantsch’s claim that the Beluzov-Zhabotinski reaction, as a result of its classification as an autopoietic system by Maturana’s definition [3], has rudimentary consciousness [2,17]. During the formal age of Behaviorism (1913~1970) consciousness was discarded as an irrelevant black box; in recent decades cognitive researchers (~1935-present) claim that consciousness is merely a specialized computer program, “a special software in the hardware of the brain or just a matter of information processing” [18]. Since we are not robots without volition this seems unacceptable; more a reflection of the current myopic bias in the field of Consciousness Studies where the dominant cognitive model is aligned with the standard mechanical model of biology which remains couched in the current Bigbang cosmology which like all contemporary models of science is based on Darwinian naturalism [65]. This *philosophy of biological mechanism* provides only half the story of mind. Our aim is to show that an addition to and clarification of Maturana’s key leads to a complete definition of SOLS and suggests that the prion [19,20] should be classified as the only truly mechanical form of living system. The prion then is the zero point or zeroth case of a living system. But this means it should not be classified as purely mechanistic like the Beluzov-Zhabotinski reaction because the Beluzov-Zhabotinski reaction does not utilize either the *élan vital* or machinery of a living system as viruses and prions do.

The *cognitive domain* [3] of a prion¹ does not create and dissipate entropy in its own right as higher life forms do. The prion is not at the same level as a virus where this critical factor of far from equilibrium complex processing is satisfied vicariously when viral proteins commandeer existing cellular machinery of the host. The prion, as the zeroth case of a living system, does not ‘live’ at the viral level. It has no cognitive domain. In a sense it is like anti-life. The conformational state of the prions geometry by its very existence in proximity to normal proteins is like a match igniting gasoline. The factor that separates the prion from the non-autopoietic entities listed in section 9.2 (which utilize only the mechanistic half of the complementarity required for a complex self-organized

¹ The prion propagates through conformational changes in the geometry of its proteins molecular structure [19, 20].

living system) is the prions utilization of the existing coherent energy of the *élan vital* in its propagation. This is a prediction of noetic theory that must be demonstrated empirically [21, 71,72].

7. What About Quantum Biology

Current thinking in Quantum Theory states that the evolution of all atomic and subatomic particle interactions can be described by a Schrödinger equation pertaining to action of particles moving on a manifold

$$i\hbar \frac{\partial \psi(x,t)}{\partial t} = -\frac{\hbar^2}{2m} \nabla^2 \psi(x,t) + V(x)\psi(x,t). \quad (1)$$

The Schrödinger equation takes myriad forms. The one above is a positional representation of the equation in Cartesian coordinates where \hbar represents Planck's constant, the ∂ terms denote the time derivative with respect to the wave function ψ , m is mass, ∇ denotes the space derivative and V is the potential energy function of (x,t) .

In terms of the present status of biological theory explored in sections above it should be noted, as is generally known to physicists, that the founders of quantum theory emphatically stated that the standard phenomenological model of quantum theory (The Copenhagen interpretation) designated to describe all atomic and subatomic phenomena is incapable of describing biological systems.

Neurophysiologists have attempted modifications of the Schrödinger equation, to be used to describe trajectories of a neuronal action potential on a brain cell manifold in the neural bioplasma [22,23,24]. These extended forms of the Schrödinger equation relate to the ontological (CSI) interpretations of quantum theory developed initially by physicists de Broglie, Bohm and Vigier [81]. The ontological interpretation attempts to overcome the quantum uncertainty principle by adding an additional term to Schrödinger's equation called the pilot wave or Quantum Potential Q .

$$\frac{\partial S(x,t)}{\partial t} + \frac{(\nabla S_{(x,t)})^2}{2m} + V(x) + Q(x,t) = 0 \quad (2)$$

where the Quantum Potential

$$Q = -\frac{\hbar^2}{2m} \frac{\nabla^2 R(x,t)}{R(x,t)}, \quad (3)$$

and real functions R and S are the 'amplitude' and 'phase' respectively [22,23,24]. A reasonable step, but these incarnations of the ontological formalism do not complete quantum theory, i.e. do not extend far enough to provide the necessary substrate for intentional action missing from the standard model of quantum theory because they do not make correspondence to the unitary field which Einstein among others claimed provided the basis for all life. In describing CSI theory in 3(4)D Holland [88] briefly alludes to a "Super Quantum Potential" (SQP). In the noetic formalism if the SQP is extended to 11(12) D it can meet the requirement of being equated with the unified field.

Activity in the various structures of the neural bioplasma is considered a complex many body problem. When reduced to the molecular level only the scale has changed and the standard rules of quantum theory still seem to apply. This is the crux of the problem of biological mechanism. In mechanics, whether classical or quantum, objective analysis follows coherent lines. But in applying similar rules to biological systems there is a breakdown.

One can find little argument with these applications of quantum theory since obviously quantum fluctuations occur not only relative to all microscopic actions but also in relation to aspects of neural networks primarily because they are a quantum chemistry. But all descriptions of this type (particle activity on a manifold – what the Schrödinger equation was derived for) still represent action at the semi classical limit. As noted above – such physicochemical interactions, although under the panoply of the standard model of quantum theory, draw a line in the sand beyond which the founding fathers of quantum theory maintained that the quantum formalism offered no description of biological systems because whether linear or nonlinear, local or nonlocal there is no provision for the additional degrees of freedom that come with intentional agency – the ability to change an action once set in motion.

8. Is There More To Biology Than Mechanism?

Returning to the analysis of the fundamental philosophy of biology we summarize Brillouin's [25] historical categorization of the issues of mechanism versus teleology into three general positions:

- Knowledge of physics and chemistry is essentially complete and life could be explained without introduction of any additional *life principle* (*élan vital*).
- Considerable physics and chemistry is known, but not everything. A new law or principle needs to be discovered to explain life; but this concept will not be outside the laws of physics and chemistry already known. Whether or not this is considered a *life principle* or not is irrelevant.
- A *life principle* is mandatory for an understanding of life because living systems are considerably different and much more complex than inert matter. The laws of thermodynamics describe only inert and *dead* matter to which life is an exception requiring a new principle to explain.

Theories of mind abound with great disparity between them [4,11]. It could be said to be like the early days of electromagnetism when ‘for every 100 theorists there were 101 theories’. Simply stated, and using top-down reduction, mind theory can be categorized generally as follows:

Classical Reductionism – Newtonian mechanics deemed sufficient to describe mental activity

- Neural action – Consciousness can be completely explained by neuronal brain processes.
- Digital computer-like information processing in Neural Networks / Cellular Automata / Common laws of Physics and Chemistry.

Heisenberg Cut – Additional quantum degrees of freedom, possibility of nonlinear & nonlocal interactions

- Quantum computation in brain microstructures like synapses, microtubules or ordered water.
- Copenhagen statistical phenomenology – collapse of wave function essential for mental activity.

Cartesian Cut – requires additional ‘life’ and/or physical principles beyond mechanistic theories

- Dualism / Interactionism – ontological extensions of quantum theory, evolution of the wave function without collapse.
- Monism – all is mind, consciousness is ineffable and immaterial.

The first four types above fall under the domain called the philosophy of biological mechanism. Theories in the Classical and Heisenberg arenas have defined consciousness as a hard problem too difficult to research [22,26]. This provides significant motivation to explore below the Cartesian divide where additional physical laws are anticipated. What evidence exists to justify such a search?

Continuing with the premise that quantum theory is incomplete, Schrödinger in relating the 2nd law of thermodynamics and life says: “We cannot expect that the ‘laws of physics’ derived from it to suffice straightway to explain the behavior of living matter... We must be prepared to find a new type of physical law prevailing in it. Or are we to term it a non-physical, not to say a super-physical law [27]?”

But what can this new physical law be?

9. Complex Systems Theory: A New Model For The Origin Of Life

Scientists unanimously consider unicellular prokaryotes (no nucleus, as opposed to eukaryotes with nucleation) as the most fundamental form of living system with the inclusion of viruses remaining controversial [64] because ‘karyotes have cellular boundary conditions to demark the substance of a living system. Viruses commandeer the boundary conditions and prions demonstrate the mechanical properties driving action. By defining awareness as a fundamental physical quantity like the concept of *charge* in electrodynamics [10,28,29], it is possible to show how the prion recapitulates, in the sense of its organization, the propagation of its infective state by maintaining the ‘charged’ form of its conformation merely by being coupled to the Noetic Field in proximity of higher order SOLS. Prion propagation therefore represents biological mechanism in its most fundamental form and provides the root of its redefinition. Although slightly more complex, the self-organization pertinent to viral replication also falls under this new definition of biological mechanism. Something different happens at the level of bacteria or perhaps any motive unicellular life form. The cognitive domain has sufficient capacity for activity based on an *interactive computational model* [30]; the evolution of the ‘minds’ content (qualia) is driven by more than the mere presence of teleology as in the case of the prion or virus, i.e. more degrees of freedom are available.

Our view of a ball bearing or marble is that they are spherical globs of elemental iron or quartz molecules. A more detailed case has been made elsewhere [10] that the HCM is self-organized and comprised of a system of scale invariant (same order from micro to macro) least units that in principle are like standing waves of their fundamental components. We call this a *continuous state* and claim that it is a fundamental self-organizing principle of the universe like charge. The very existence of this continuous state least unit allows it to be classified as an action principle because it entails a force to continuously produce and maintain coherence. The symmetry enhancing nature of the force acts not only on the topological states of prion conformation by constructive interference as the base state of biological mechanism, but also by higher order conditions of self-organization (defined in section 9.1). The structural-phenomenology of this new noetic action principle [9] is a complementarity of mechanism and the unified noetic field (we call the unified field noetic because it is a field of consciousness), together forming a teleology that is the general driving principle governing all aspects of complex SOLS [21]. Applying the concept of a *unit cell* from the nomenclature of crystal structure to this fundamental teleology in the topology of spacetime forms the scale-invariant hierarchical basis of living-systems from the microscopic origins of mechanism to macroscopic intentional systems like the mind of Man. The complementarity of mechanism and teleology is a structural-phenomenology that is the primary cosmological principle of the conscious universe; the fundamental least unit of which is defined as awareness [10,12].

Defining awareness as a fundamental principle like charge in Electromagnetic Theory [10,17] provides a path to formulate a theory of life and consciousness. The currently popular cognitive avenue poses the question ‘*what processes in the brain give rise to awareness?*’ Unfortunately this creates what has been defined as the *hard problem*, which is deemed impossible to study empirically [26,89] - an investigative dead end! Charge has been considered a physically fundamental and indivisible concept; but this definition appears to hold only to the semi-classical limit. Physicists are finding out that the so-called unit of elementary charge arises from a deeper wormhole structure in the higher dimensional topology of spacetime [31]. This is also true in defining the fundamental unit of awareness. Charge, or in this case awareness, does not arise as a brain process. Only looking beyond the brain into spacetime leads to a model of awareness (consciousness) that is both definable and empirically testable. In brief, the fundamental basis for the least unit of awareness is a cosmology that has three complementary components [10,29]:

- Elemental Intelligence – A non-local atemporal HD domain, which is a set of boundary conditions co-eternal with God that define the fundamental limits of an individual entity.
- Noetic Ordering Principle – A new atemporal or eternal action principle synonymous with aspects of the unified field and mediated by an exchange particle called the noeon that is synonymous with chi, prana or spirit or a life principle (*élan vital*).
- Localized Fermi and Bose brain/body States – Classical, semi-classical and quantum temporal modes associated with neural activity and other aspects of simpler autopoietic or complex SOLS.

Remaining problems center around the fundamental nature of space; suffice it to say that Einstein’s superceding of Newton’s 3D absolute space with a 3(4)D relativistic space was a significant milestone, but not a final answer. The triune complementarity above provides a sufficient structural-phenomenology of when cast in the 11(12) noetic space to define the psychosphere of an individuals mind and body because 12D is the minimum number of dimensions needed to describe eternity [77].

10. Action Of The Unified Noetic Field

Fröhlich [32] proposed a new energy that produces coherent long-range order in biological systems. Some authors have suggested this coherence is a type of Bose condensate². Einstein and Hagen [33] further postulate this coherent principle arises from the unified field, which is also proposed here by Noetic Field Theory. The action of the unified field is the basis for a life principle governing the evolution of complex SOLS.

We will show generally how the continuous transformation of the topology of the 11(12)D superspace of the noetic least unit introduces by periodic holophote³ action evanescence of a life force from the HD energy covering of each virtual moment of the present [9,10,12]. First we illustrate one of a number of possible models of how at the

² Light-like state as opposed to Fermi state limited by the Pauli exclusion & Heizenberg Uncertainty Principles (see [89] for detailed discussion of how Bose condensates are produced from Fermi Brain states).

³ Holophote – flashing like a light house

semi-classical limit from the stochastic background of the vacuum zero-point field, this energy of the *élan vital* is harmonically injected into every point and atom in spacetime by a mechanism like a ‘chaotic gun’ [34,35].

Using equations for a chaotic gun developed by Ciubotariu [9,31,34,35] the nonlinear dynamics of the model for injecting a charged noeon into a spacetime cavity can be described as follows:

$$\dot{X} = \frac{dX}{dT} = \frac{1}{\gamma} P_x = \frac{1}{(1 + P_x^2 + P_y^2)^{1/2}} P_x, \quad (4)$$

$$\dot{P}_x = \frac{dP_x}{dT} = \Omega_c [\beta \cos(X - T) + 1] P_y, \quad (5)$$

$$\dot{P}_y = \frac{dP_y}{dT} = -\Omega_c [\beta \cos(X - T) + 1] P_x + H \cos(X - T), \quad (6)$$

Equations (4 to 6) illustrate a possible quantum model for entry of the new noetic action principle into the 3D phase space P_x, P_y, X where photons of the Noetic field (noeons) are injected into each point (least unit) in spacetime and every atom by a periodic ‘gun effect’ of the continuous holophote action. This is a continuous state spin-exchange dimensional reduction compactification process inherent in the topology of Noetic Superspace [9,10,11] acting like a hysteresis loop. Ciubotariu’s equations combine Maxwell’s equations and relativistic equations of motion for the phase space P_x, P_y, X . The Ω terms represent the cyclotron frequency of the chaotic gun effect. Infusion of the noeon Boson (photon) field mediating action of the life-force in spacetime cavities only occurs in certain preferred directions allowed by the symmetry conditions of what is called parallel transport in the dimensional reduction compactification process [9,10].

The holophote effect appears in the Noetic cosmology because in its energy dependent spacetime metric \hat{M}_4 [10], just as a periodicity of wave and particle moments occur in photon propagation through space, so does charge or energy arise in periodic moments of the Noetic least unit transformation (see Fig. 9.1). Because as Wheeler showed in 1962 [36] ‘charge is topology’. According to Wheeler [36] lines of force in a wormhole can thread through a handle and emerge through each mouth to give the appearance of charge in an otherwise charge free spacetime.

Each mode of the field of a quantum harmonic oscillator is associated with the quantum cavity dynamics (Cavity-QED) of the spacetime topology as it undergoes its continuous state transitions.

$$E_n = (n + \frac{1}{2}) \hbar \omega \quad (7)$$

E is the state of energy for n photons. For $n = 0$ the oscillator is in the ground state; but a finite energy $1/2 \hbar \omega$ of the ground state, called the zero-point energy, is still present in the region of the cavity. According to equation (7) of the quantum harmonic oscillator the field energy of the photons undergo periodic annihilation and recreation in the periodic symmetry of noetic spacetime [37].

11. Mechanism Of Protein Conformation In Prion Propagation

Fatal neurodegenerative disorders known as transmissible spongiform encephalopathies (TSE’S) have been shown to spread by a proteinaceous infectious particle dubbed the prion [19,20,38,39]. According to Prusiner’s definition these prion elements propagate conformational variation leading to replication by a mechanism not well understood until recently [20]. Two conversion hypotheses have been proposed:

- The *template-assisted conversion model* [40] where a putative cellular chaperone called protein X assists conformational transition by altering the thermodynamic equilibrium of a kinetic barrier in favor of transition state protein formation.
- The *nucleation-polymerization model* where highly ordered aggregates of the infectious element form. This also shifts thermodynamic equilibrium allowing this nucleus to act as a seed for further prion propagation. Protein folding thus appears in both cases to be the primary autocatalytic mechanism propagating prion diseases.

According to Prusiner [39]:

Nascent prions are created either spontaneously by mutation of a host protein or by exposure to an exogenous source. Prions are composed largely, if not entirely, of a modified form of the prion protein (PrP) designated PrP^{Sc}. Like other infectious pathogens, they multiply but prions do not have a nucleic acid genome to direct the synthesis of their progeny. A post-translational, conformational change features in the conversion of cellular PrP (PrP^C) into PrP^{Sc} during which alpha-helices are transformed into beta-sheets. Since this structural transition in PrP underlies both the replication of prions and the pathogenesis of the CNS degeneration, much of the effort in the laboratory is devoted to elucidating the molecular events responsible for this process. Indeed, prion diseases seem to be disorders of protein conformation. @

And further relative to the theory of prion propagation proposed here:

During prion replication, an as yet to be identified factor that we have provisionally designated protein X binds to PrP^C. The PrP^C/protein X complex then binds PrP^{Sc}; by an unknown process, PrP^C is transformed into a second molecule of PrP^{Sc} [39]. @

A Postulated 3D X-bundle structure of the PrP^C was chosen by Prusiner from four penultimate PrP^C models reduced from ~300,000 possible configurations by both theoretical and experimental constraints. These four choices correlated best with human prion mutations. A Conceptual model of the orientation of the four helices of the X-bundle model looks like two X's nearly superimposed on each other. Since prions have no nucleic acid based genome to direct their propagation. Noetic theory proposes that prion replication is directed by fundamental mechanisms of complex systems theory and that the action principles driving complexity are a more fundamental form of mechanism (stated in 9.4) than that perceived currently by the philosophical basis of mechanism in biology.

12. Physical Cosmology Of The Fundamental Least Unit

Crystals are built up from unit cells, which are like bricks, bonded together to form the crystals structure. The same is true of cosmological models [59]. Modern Bigbang cosmology is said to be comprised of Planck scale least units \hbar of 10^{-33} cm . Noetic cosmology introduces a modified fundamental cosmological least unit in the context of an advanced form of Einstein's model of a static universe, called the Continuous State Holographic Conscious Megaverse (HCM) [9]. If there is more to SOLS than brain cosmology is required. Since the Bigbang is a naturalistic cosmology it provides an insufficient basis for describing life. HCM cosmology is based on principles originally introduced in 1945 by the Wheeler-Feynman absorber theory of radiation [41] that proposed future – past conditions governing radiation. In 1983 Cramer developed a model of quantum theory based on the Wheeler-Feynman model. In noetic cosmology the model is extended to the topology of a highly symmetric periodic (11)12D spacetime manifold [77,78]. The fundamental *least unit* is described as a scale invariant complex self-organized cosmological system. This means the noetic least unit (why it's termed noetic) includes autopoietic principles of “awareness” [10-11,17]! The main difference is that rather than being fixed fourteen billion years ago in a primordial singularity, boundary conditions translate as a *continuous state* in a spin exchange dimensional reduction compactification process inherent in what Dirac defined as a covariant polarized vacuum [90]. As will be developed in detail below this topology is defined mathematically by coupling what are called superluminal Lorentz boosts with a form of noncompactified Kaluza-Klein theory [42] in the context of an energy dependent Minkowski spacetime metric \hat{M}_4 (see eq. 12). This whole concatenation is required so that reality may take the form of (11)12D standing wave; which is required to introduce teleology in a fundamental way.

13. Euclidian / Minkowski Geometry As The Basis For Reality

The Euclidian line in 3D space is assumed to be the real line [43] because it is what is observed. Logical reasons from supersymmetry and supergravity suggest there are a number of additional unobserved dimensions [42] leaving the issue of dimensionality as an open question. Euclidian space in classical Newtonian mechanics is a continuous 3D absolute space with time an independent parameter often considered irrelevant.

Einstein's relativity theories provided a discrete 3(4)D transmutable relational spacetime manifold. The debate between absolute space or substantivism and relational space still continues. Utilizing the standard definition of a straight line as the intersection of two rigid planes, measurements could be taken to observe whether the angles of a

triangle add up to 180° ; but settling the question definitively is a cosmological issue requiring astronomical scale measurements where it appears physically impossible to apply the concept of a rigid body or to define a straight line in terms of a light ray by stellar parallax because of the effects of general relativity. Therefore all physics knows with certainty at the present time is that observed space is approximately Euclidian E_3 as is Einstein-Minkowski space $M_{(3)4}$ [42,43].

According to the proof of Schöenflies theorem [44] there can be no topological knots in a 2D plane. Therefore there can be no topological torsion (gravitation) in a 2D reality; thus the observed real line must be at least 3D Euclidian where the standard Pythagorean line element is

$$ds^2 = dx_1^2 + dx_2^2 + dx_3^2 \quad (8)$$

This assumption that the Euclidian line is the real line is intuitive. Currently there is no known method of empirical proof; and since the Euclidian line is what the Human mind apprehends it remains the formal basis for all empirical scientific fact [43,45]. But this assumption remains profoundly problematical with issues stemming from both the foundations of mathematics and developments in the nature of physical theory itself concerning the fundamental basis for sets, discreteness versus continuity, geometry and topology, and the relationship of real numbers to rational numbers for example [43].

In general, the class of theories unifying gauge and gravitational fields by utilizing extra dimensions is called Kaluza-Klein theories. In these theories what is called spontaneous symmetry breaking by coordinate transformation starting in 5D is a product of the standard 4D transformation and a local U(1) gauge group arising in basic form in a general relativistic framework of five dimensions described according to the Einstein-Hilbert action

$$A = \int d^5x \sqrt{g} R. \quad (9)$$

Where instead of postulating a 5D Minkowski space M^5 as the ground state, the ground state is taken to be the product $M^4 \times S^1$ where a circle S^1 is a U(1) group of rotations [42]. In conventional supersymmetry models like String Theory the radius of circle S^1 is considered to be microscopically small (compactified at the time of the Bigbang) on the order of the Planck scale (10^{-33} cm , 10^{-43} s), very short and very fast, explaining why these extra dimensions are not observed. This will be discussed in more detail below where Planck's constant is recalculated utilizing the Larmor radius of the hydrogen atom as it relates to non-compactified Kaluza-Klein theory [42] in the 12D Wheeler-Feynman context [9,41].

An $SU(3) \times SU(2) \times U(1)$ gauge symmetry group can be used to describe all known particle interactions. Following Witten, [43] the *minimum* number of dimensions of a manifold with this symmetry is seven. In this $SU(3) \times SU(2) \times U(1)$ symmetry group gauge fields arise in the gravitational field as components of more than four dimensions. This yields a dimensionality for our reality of at least four non-compact and seven compact spacetime dimensions, $M^4 \times S^7 = 11D$; which Witten [42] calls a remarkable numerical coincidence since this 11D maximum for supergravity is the minimum for $SU(3) \times SU(2) \times U(1)$ symmetry which also for symmetry reasons observed in nature is in practicality the largest group one could obtain from Kaluza-Klein theories in seven additional dimensions.

This gauge group for gravitational field components is insufficient to describe nature; for a complete theory quarks and leptons plus a Higgs type mechanism triggering symmetry breaking must be added to the Kaluza-Klein framework. In attempting to complete the theory, the gauge coupling constants are determined by calculating the Einstein action over the compact dimensions. This scales at a high power of $1/(M_p R)$, where M_p is the Planck length and R is the radius of the extra dimensions showing that R must actually be in the 10^{-33} cm range for these standard model gauge theories. If one adds the Lagrangian of a cosmological constant Witten finds one can form a reasonable theory [42].

Noetic Cosmology relies heavily on the relational 11D symmetry described by Witten with a different view of compactification because the Einstein gauge is both classical and incomplete as formulated in terms of the Darwinian naturalism of the Bigbang. However Noetic Cosmology like any new theory must however make correspondence to the established Einstein gauge. To do this a new 12D absolute space is postulated as the eternal basis for a (11)12D relational spacetime manifold that makes correspondence to Witten's supersymmetry model. To assume that the extra dimensions are compactified to the Planck scale because they are not observed is only one theoretical choice. The relativistic processes of the continuous state also allow large-scale dimensions to appear invisible. For example when I a Noeticist open his eyes in the morning to get out of bed it is a complicated scenario.

Firstly his eyeballs are pressed against an atmosphere with a force of 14.7 pounds per square inch. He must put his foot on a floor that is traveling 19 miles per second around a yellow-green thermonuclear fireball. The floor is not solid; it is 90% empty space, made of tiny charges called electrons spinning near the speed of light that he is supposed to believe are mathematical constructs called 2-spinor fields. At best he is stepping onto a swarm of bees. While doing this wind of the unitary noetic field passes through every nook and cranny of his body like a tornado and animates the entelechies of his mind. Will he fall into the abyss or burst into flame? Truly as the parable states, it is easier for a camel to pass through the eye of a needle than for a scientist to get out of bed in the morning. It would be far simpler to be an ordinary man and enjoy a spot of tea than to suffer the difficulties involved in resolving these scientific issues [78].

The existing derivation of Planck’s constant represents classical mathematical limits that are not considered real physical limits in HCM cosmology. In Bigbang cosmology the universe reduces to a stochastic impenetrable Planck scale barrier. Noetic cosmology utilizes what is called an antinomy to escape the cosmological conundrum and still make correspondence to established theory. In HCM cosmology the universe is observationally closed and finite in time (the 14 billion light year Hubble radius) and open and infinite (a holographic megaverse with the possibility of an infinite number of Hubble spheres each with their own laws of physics⁴) in eternity. Since the Higg’s mechanism (for producing mass) also arises from approximations in the Einstein gauge it is also called into question and replaced by a different symmetry breaking mechanism in the noncompactified form of Kaluza-Klein theory utilized in Noetic Cosmology.

14. Overview Of The Formalism For Noetic Cosmology

Noetic HCM Cosmology is cast in an (11)12D harmonic superspace $S_N = S_0 + S_1 + S_2$ in the context of an extended Wheeler/Feynman absorber theory [9,41] where standard Einstein Minkowski space M_4 becomes an energy dependent spacetime metric \widehat{M}_4 , which is a virtual *standing wave* present of the future-past. This eternal present (\widehat{M}_4) is a 4D temporal subspace of a 12D eternal (timeless) absolute space where 12D is the minimum number of dimensions required to describe eternity⁵ [84]; and takes the general mathematical form

$$R_{symM_4}^{S_{N_0}} = \frac{1}{2} \left[R_{retC_4}^{S_{N_1}} + R_{advC_4}^{S_{N_2}} \right] \quad (10)$$

or simplistically stated the 12D noetic superspace S_N represents a complex Minkowski metric $M_4 + C_8$ (or $\pm C_4$). S_N thus combines the standard four *real* dimensions (D) of M_4 plus 8 complex imaginary D representing a *retarded* (future) and *advanced* (past) complex hyperspace topology, which adapts the complex ($M_4 + C_8$) Minkowski metric from the standard stationary form of Bigbang cosmology to a periodic form for HCM cosmology. $S_0 = M_4$ represents the noetic 3(4)D *standing wave* Minkowski ‘present’ spacetime; $S_1 = -C_{4(ret)}$ represents the past retarded component and $S_2 = +C_{4(adv)}$ represents the future advanced component for complex correspondence to the standard 4 real dimensions utilizing 8 imaginary dimensions. The 8 imaginary dimensions, while not manifest generally (locally) on the visible Euclidean real line, are nevertheless ‘physically real’ in HCM cosmology and can be represented by complex HD coordinates

$$X = \pm(x + i\xi), Y = \pm(y + i\eta), Z = \pm(z + i\zeta) \quad \text{and} \quad t = \pm(t + i\tau) \quad (11)$$

designating correspondence to real and \pm retarded/advanced continuous spacetime transformations. For symmetry reasons the metric for the standard Minkowski line element $ds^2 = g_{ij} dx^i dx^j$ is expanded into periodic *retarded* and *advanced* topological elements fundamental to the ‘extension’ of relational space giving Noetic Superspace S_N its continuous state dimensional reduction standing wave periodicity. This is illustrated conceptually in Fig. 9.1 below.

⁴ In an eternal conscious megaverse the observational limit and laws of physics are determined by the quantity of souls occupying the particular creation, i.e. “Adam was given his reckoning” [see 78].

⁵ By eternity here we mean to be causally (or ontologically) free of events in M_4 or local observed reality.

The Kaluza-Klein model utilized is set in a noncompactified $D = 12$ harmonic Noetic Superspace S_N and is the foundation of a holographic conscious megaverse. For symmetry reasons shown in the text this superspace comprises an 11D hypersurface in a 12D megaverse, giving it theoretical correspondence to the 10D superstring theory and 11D supergravity of M-Theory or 12D F-Theory providing a context to solve the disparity between them. The appeal of Kaluza-Klein models is that physics seems simplified in HD, especially integration of the electromagnetic (EM) and gravitational fields [46,47].

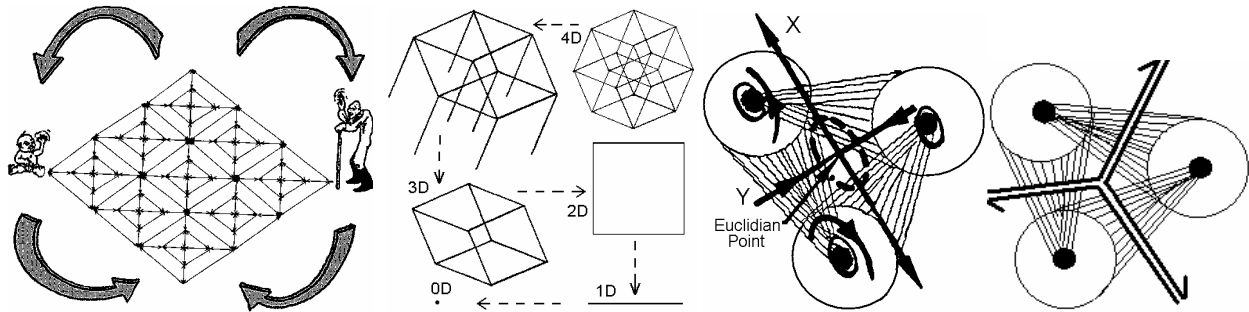

Figure 2. Four conceptual views of underlying reality representing topological premises of the fundamental least unit of Noetic Cosmology derived by applying extended Wheeler/Feynman absorber theory: a) Baby and old man represent the *relational* periodic basis of the present as a future-past standing wave illustrated simplistically as a 2D spacetime sheet. b) The 12D harmonic superspace translates in a continuous state dimensional reduction spin exchange compactification process from 12D to 0D by parallel transport of the boundaries (only a 4D translation shown for simplicity). c) A 3-torus illustrating continuous creation and annihilation of a discrete virtual standing wave Euclidian point (P_E); which would be denoted as \hbar by current thinking in terms of the standard model. But in HCM cosmology the least unit is the whole structure and has a harmonic radius governed by the string tension equation and oscillates from \hbar at 10^{-33} cm to the Larmour radius of the Hydrogen atom 10^{-15} cm . The additional 9D are suppressed for simplicity. d) Another least unit view where the vertex is modeled after string theory to flip like an Ising lattice. All seven figures in 9.1 & 9.2 are different conceptual views of the least unit [78,87]. A ‘least unit’ of Noetic cosmology represents periodic future/past transactions [41,77-8,85] as continuous cycling of *classical* \rightarrow *quantum stochasticity* \rightarrow *fundamental unitarity* ($R_C \rightarrow R_Q \rightarrow R_U$) in a D reduction spin exchange compactification Ising model $D_s \rightarrow D_t \rightarrow D_E$ transformation process, where a Euclidian Point $P_E \rightarrow \hbar$ [9].

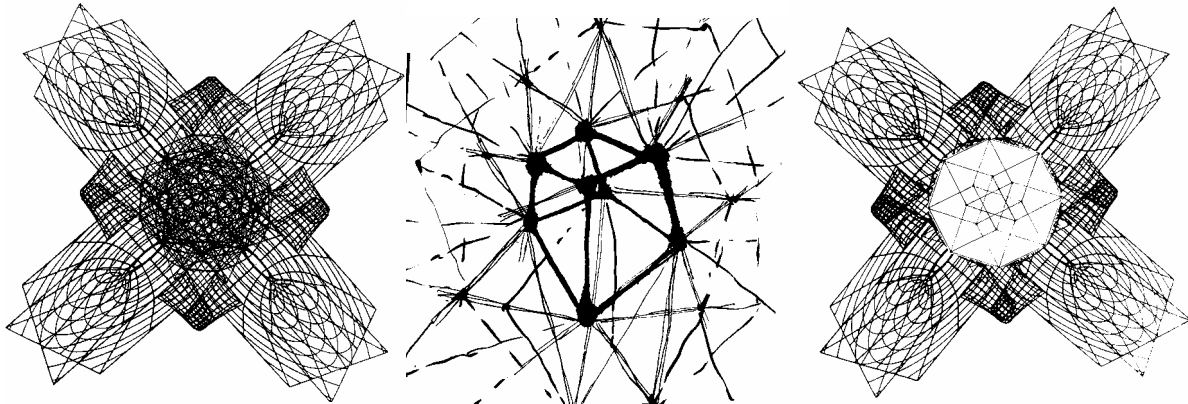

Figure 3. Additional conceptualizations of 12D least units from three hierarchical perspectives, representing time-like slices in the causal stochastic interpretation of QT [81] from the HCM point of view. a) The central circle represents a 3D microscopic view of nonlocal Planck scale stochasticity. The outer cross hatched square represents closed spacetime tubes in the process of compactification form 3(4)D to 0D. The larger diameter open tubes represent compactification from 11D to 4D, i.e. the megaverse is closed in time and open in eternity. b) A local 3D cube representing our observed virtual reality as a relational standing wave created or emerging from the continuous state background. c) The central hypersphere (here a simplified 4D representation of a 12D hypercube) represents

the atemporal hidden supralocal extra HD covering of the standing wave present in b). Again the larger peripheral spacetime tubes represent open dimensions oriented toward the future; and the narrower coupled tube forming a cross hatched square represents a phase of recessional compactification $P_E \rightarrow \hbar$ toward the past, the final phase of which would end up like Fig. 1c,d) – a virtual Planck scale singularity.

While only glossed over here, these concepts are challenging problems for physical cosmologists. For example string theorists believe extra dimensions (XD) must be ultramicroscopic because they are not observed. In a movie theater, discrete frames of film move across the projector lens at only a few cm/sec. but the image observed on the screen appears continuous to our senses. Matter all around us (and comprising us) moves FAPP infinitely faster near light speed. More than enough velocity to allow continuously compacting XD to appear invisible; so it is only a disagreement of interpretation. If the noetic alternative is the true case immediate and profound implications arise: Plank’s constant is not fundamental, there are no magnetic monopoles, supersymmetric partners; there is no Higgs mechanism or quantum gravity, and the photon has minute mass [9]! All supporting a conscious megaverse.

Figure 9.2 hints why the Planck constant needs to be recalculated. Standard measurement techniques create the uncertainty and Pauli Exclusion Principles by discretising angular momentum and in that sense are Fermi-like and past (compactification) oriented causing the Planck constant to be applied as usual as a fundamental barrier. Because “Quantum mechanical uncertainty is the mystery; even the mystery of God” [86]. In the unmeasured, the *eternal now* (Schrödinger Cat Paradox), the Planck constant takes the form of the Larmor atomic radius and is an unbounded open component of the unitary field in the future orientation. In this HCM model Planck scale stochasticity arises in the temporal wake of graviton propagation⁶, i.e. the continuous state spin exchange dimensional reduction process (12D to 4D to 0D). Or viewed in another way the 12D superspace is a coherent structure like the frame of a building, which when demolished collapses into a stochastic pile of rubble.

Highly ordered, harmonic, symmetric and periodic Noetic superspace S_N entails a continuous-state dimensional reduction spin exchange compactification process operating under a new set of transformations beyond the standard Lorentz/Poincaré [11] where spatial dimensions D_S transform through superluminal boosts into temporal dimensions D_t ; and by further boosting in terms of noncompactified Kaluza-Klein modeling [42,47] into energy dimensions D_E denoted $D_S \rightarrow D_t \rightarrow D_E$. This requires the properties of an energy dependent spacetime metric as first developed by Einstein. In the model standard Einstein Minkowski space M_4 becomes instead a topologically invariant homeomorphic manifold of the energy dependent spacetime metric \hat{M}_4 for HCM cosmology.

$$f : M_4 \rightarrow \hat{M}_4 \quad \text{and} \quad \hbar \Rightarrow \hat{N}_R \quad (12)$$

where \hat{N}_R is the continuous state average of the fundamental least unit of noetic superspace purported to harmonically oscillate from the Plank radius \hbar 10^{-33} cm to the Larmour radius of the Hydrogen atom 10^{-15} cm [9].

According to the principle of relativity a spacetime region that is a ‘perfect vacuum’ (no matter or fields) must be isotropic and covariant in the Lorentz sense [43]. The deformed region \hat{M}_4 of S_N and the symmetry of S_N itself reduce to Einstein’s relativistic metric and are assumed compatible with Dirac’s polarized covariant vacuum [48].

15. Transformation Of Space Into Time

It is well known that Superluminal Lorentz Transformations (SLT) can mathematically change real quantities into imaginary ones. Following Cole [49] and Rauscher [50] we illustrate the transformation of complex spatial dimensions into temporal dimensions by orthogonal superluminal boosts (SLB). For example an SLB in the x direction with velocity $v_x \pm \infty$, the SLT is $x' = \pm t$, $y' = -iy$, $z' = -iz$, $t' = x$. In complex Minkowski space the coordinates are $z^u = x_{\text{Re}}^u + ix_{\text{Im}}^u$ where z is complex and x_{Re} and x_{Im} are real and index u runs over 0,1,2,3. Using classical notation for simplicity one then obtains

$$t = t_{\text{Re}} + it_{\text{Im}}, \quad x = x_{\text{Re}} + ix_{\text{Im}}, \quad y = y_{\text{Re}} + iy_{\text{Im}}, \quad z = z_{\text{Re}} + iz_{\text{Im}}. \quad (13)$$

⁶ In the Noetic Megaverse the graviton becomes synonymous with the unified field, which is synonymous with the spirit of God, chi or prana.

To clarify the meaning of imaginary quantities in an SLT it is helpful to represent time as the 3D vector t_x, t_y, t_z ; therefore time is defined as $t = t_x \hat{x} + t_y \hat{y} + t_z \hat{z}$ where

$$t_x = t_{x\text{Re}} + it_{x\text{Im}}, t_y = t_{y\text{Re}} + it_{y\text{Im}}, t_z = t_{z\text{Re}} + it_{z\text{Im}} \quad (14)$$

Finally for the SLB for velocity $v_x \pm \infty$ along x the transformations are

$$\begin{aligned} x'_{\text{Re}} + ix'_{\text{Im}} &= t_{x\text{Re}} + it_{x\text{Im}}, y'_{\text{Re}} + iy'_{\text{Im}} = y_{\text{Im}} - iy_{\text{Re}}, z'_{\text{Re}} + iz'_{\text{Im}} = z_{\text{Im}} - iz_{\text{Re}} \\ t'_{x\text{Re}} + it'_{x\text{Im}} &= x_{\text{Re}} + ix_{\text{Im}}, t'_{y\text{Re}} + it'_{y\text{Im}} = t_{y\text{Im}} - it_{y\text{Re}}, t'_{z\text{Re}} + it'_{z\text{Im}} = t_{z\text{Im}} - it_{z\text{Re}} \end{aligned} \quad (15)$$

where the SLT in x of M_4 spacetime transforms real components into imaginary ones and imaginary complex quantities into real quantities illustrating a major property of the periodic nature of Noetic spacetime [49,50, 78].

16. Energy Dependent Spacetime Metric

Einstein originated the concept of an energy dependent spacetime for explaining temporal rate changes in the presence of a gravitational field by generalizing the special relativistic line element (compare equation 2)

$$ds^2 = (1 + 2\phi/c^2)c^2 dt^2 - dx^2 - dy^2 - dz^2 \quad (16)$$

with the introduction of time curvature [51,52] where ϕ is the Newtonian gravitational potential. This utilizes the deformed Minkowski metric \hat{M}_4 (introduced by eq. 5) above which is imbedded in the periodic HD Noetic space S_N chosen axiomatically for HCM cosmology to take the form of a noncompactified Kaluza-Klein theory [42,47].

Kaluza's initial demonstration of gravity in 5D, ${}^5G_{AB} = 0$ with AB running 0,1,2,3,4 contained the usual 4D General Relativity with an EM field ${}^4G_{\alpha\beta} = {}^4T_{\alpha\beta}^{EM}$, with α, β running 0,1,2,3 [47]. The currently less common non-compactified Kaluza-Klein model is utilized by Noetic Cosmology where dependence on the extra D is also required. This yields the same result for Einstein's equations ${}^5R_{AB} = 0$ except that the EM energy momentum tensor ${}^4T_{\alpha\beta}^{EM}$ is replaced by a general one ${}^4T_{\alpha\beta}$ instead [47]. Sections 9.6 & 9.7 demonstrate the feasibility of an energy domain pervading HD spacetime with properties similar to Wheeler's Geon [53] which is developed here as the unified field. In a generalized deformed spacetime \hat{M}_4 , spacetime is fixed by the energy and has the metric

$$\eta(E) = \text{diag.}(a(E), -b(E), -c(E), -d(E)). \quad (17)$$

Skipping the mathematics for brevity and because it is similar; in the same manner that space is transformed into time by the special SLT, complex time may be boosted again by the noetic transformation into an HD causal energy covering of each least cosmological unit ($D_S \rightarrow D_t \rightarrow D_E$). This energy could be called a super quantum potential and is an aspect of the unified field.

17. Dirac Spherical Rotation And Transformation Of The Least Unit

The Dirac dual spinor (4π) rotation applies to the observation that an electron undergoes 720° of rotation (not the usual 360° or 2π rotation) before returning to the initial orientation. Traditional thinking has assumed this to be some property of matter. But the discovery of the complex structure of spacetime has shown that this is not merely a property fundamental to the electron; but additionally a property of the superspace the electron is imbedded in and an inherent part of. Dirac spherical rotation as this is also called, is more fundamentally a primary property of space than of matter. This is revealed in the complex hierarchical structure of the least unit of Noetic superspace discussed here.

18. The Dirac String Trick Demonstrates Spherical Rotation

There are simple ways to illustrate spherical rotation (Fig. 4). Tie the four corners of a square to another larger square by loose string, (alternatively, tie the initial square to the four corners of a room). Now rotate the plane of the small square or cube clockwise or counter clockwise by 360 degrees about a vertical axis, that is, in a horizontal

plane. The strings will become tangled, and it is not possible to untangle them without rotating the square back to its original position.

If one rotates the square through another 360 degrees, for a total of 720 degrees in the e direction; it is now possible to untangle the string without further rotation of the square by simply allowing enough space for the strings to be looped over the top of the square! It's hard to believe unless you try it. Use paperclips to attach the strings or ribbons to the squares, so they can be undone easily if it gets too tangled. A similar idea works for a rotation through 720 degrees about any other axis [54].

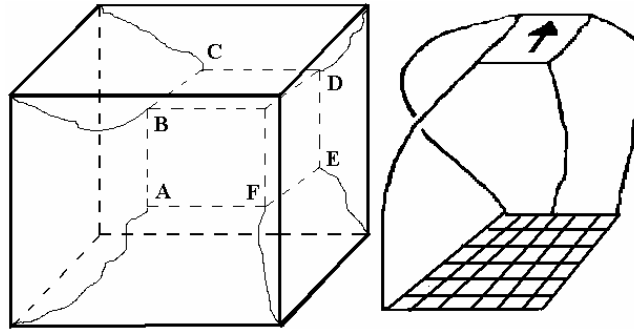

Figure 4. Two demonstration versions of Dirac spherical rotation for demonstration.

Another version of the Dirac string trick is called the Philippine wineglass dance. A glass of water held in the hand can be rotated continuously through 720 degrees without spilling any water. These geometrical demonstrations are related to the physical fact that an electron has spin $1/2$. A particle with spin $1/2$ is something like a ball attached to its surroundings with strings. Its amplitude changes under a 360 degree (2π) rotation and is restored by rotation of 720 degrees (4π). The formal description of such complex phenomena typically requires sophisticated mathematics (algebra, group theory, topology, quaternions...) since Dirac rotations are not part of everyday experience.

19. The Noetic Spacetime Transformation

As stated above Noetic cosmology implies that the so-called ‘real space’ that we observe is in essence a virtual reality much like that simulated in theme park rides or by donning computerized gaming visors. This relational standing wave spacetime is a 4D subspace of an absolute HD space, where a continuous state dimensional reduction compactification process is central to the scale invariant periodic geometric structure. It is useful to initiate the description by introducing a toy model of the lower D space and build it up to the actual 12D Noetic space.

Maintaining extended Wheeler-Feynman properties of the present as a future-past function (Figs. 1 & 2; eq. (4)) we begin by describing a discrete Einstein type point in the relational spacetime manifold. Since points are defined as singularities where dimensionality breaks down, a dimensionless point cannot be ‘covered’. This property is a valuable criteria providing a ‘hole’ or fiducial for oriented orthogonal superluminal boosts in the noetic transformation. This also contrasts the nature of continuity (Absolute space) with discreteness (relational space) [87]. Points are not absolute because the universe as now well known is not a fixed 3D Newtonian continuum.

20. The 1D Case

Therefore we begin construction of dimensionality with the 1D scalar case. Assuming an arbitrary, discrete, infinitesimal, oriented least unit $h = \Delta x$, an entourage of additional HD’s are required to ‘cover’ or geometrically confine each subspace level. ‘Covering’ is the addition of HD (n+1) topological or geometric boundary conditions that enclose the (n) lower D as a subspace of the (n+1D); essentially sealing it from any external influence except by specific oriented directions under control of the HD cover like guidance by the quantum potential. Usually the covering entourage has one more D than its subspace. The 1D least unit h , a line segment on coordinate x , can be covered by a 2-torus when the orthogonal generating circle A , of radius r located a distance $R > h_{\Delta x}$ from x_0 and not on h is rotated through orthogonal dimension y into a new plane x, y . Thus a 2D flat torus covers the least unit $h_{\Delta x}$ with an x, y plane. The rotation through y (of growing importance later) may occur in counter propagating

directions. Finally the 1D case utilizes a $\pm 2D$ covering for the $h = \Delta x$ unit of extension, which may wink in and out of existence since it is a complementarity of 0D and 1D compactification and Ising model boosting [96].

21. The 2D Case

Covering the least unit of a plane $h = \Delta x, \Delta y$ uses a method similar to the 1D case except that two complementary modes of covering are allowed:

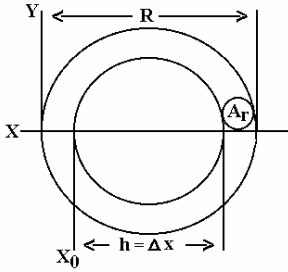

Figure 5. The 2-torus appearing as a donut slice acts as a covering of an infinitesimal 1D topological least unit $h = \Delta x$ symbolically as in fig. 1 & 2. A point of $h = 0$ (the 0D case) is dimensionless and cannot be covered (or confined). But $h = \Delta x$, acting as a transient 1D unit of extension, may be covered by a 2-torus. Generally one additional dimension is required to cover n of the next lower D space.

Type 1. Energy –Time. An intermediate covering of the planar region h by a $\pm 2D$ flat torus in the plane x, y as in the 1D case which leaves room for access of a 3rd energy or time coordinate utilizing either the spin exchange dimensional reduction process or superluminal boost into HD.

Type 2. Spatial. Region $h = \Delta x, \Delta y$ is completely covered by a 3-torus. This occurs by rotating a generating circle orthogonal to x, y through the z direction. With the addition of time as a fluid or flux dimension this covering represents the lower limit of standard (3)4D Einstein-Minkowski space M_4 .

There isn't much utility in developing our toy model all the way to 12D as pertinent aspects of the noetic transformation are now sufficiently illustrated showing how boundary conditions transform the dimensionality of space and time along with appearance of the piloting energy potential (covering) of the unified field by $D_s \rightarrow D_t \rightarrow D_e$ boosting. The unified field governs gravitation, and the quantum potential guides the action of translation along certain allowed pathways. For example, if either l, w or h is removed from a 3D cube the geometry of the object collapses or transforms to a 2D plane. Removing one dimension from the plane causes compactification to a line and so on until the 0D Ising lattice regeneration point is reached. The released spaces are not initially empty. They act as hysteresis loops. At the first stage of D reduction space transforms into time; at the second stage time transforms into the energy that couples with the energy governing it as compactification is completed for that particular least unit. Of course no least unit exists alone; they are inseparably imbedded in and as the geometry of space and spacetime and like in $e = mc^2$ become matter and energy over and over again.

22. The Permutation Of Dimensions In The Noetic Transformation

Only certain pathways for parallel transport by spin exchange dimensional reduction (D down scaling) and superluminal boosting (D up scaling) are allowed by the Noetic extension of the Wheeler-Feynman symmetry breaking relations in the continuous maintenance of the HCM cosmology of a standing wave present.

It is useful to clarify the utility of the dual covering modes in terms of parallel transport and the Regge equations relation to the Bianchi identity of a boundary of a boundary being equal to zero ($\partial \circ \partial \equiv 0$) [54,55,56].

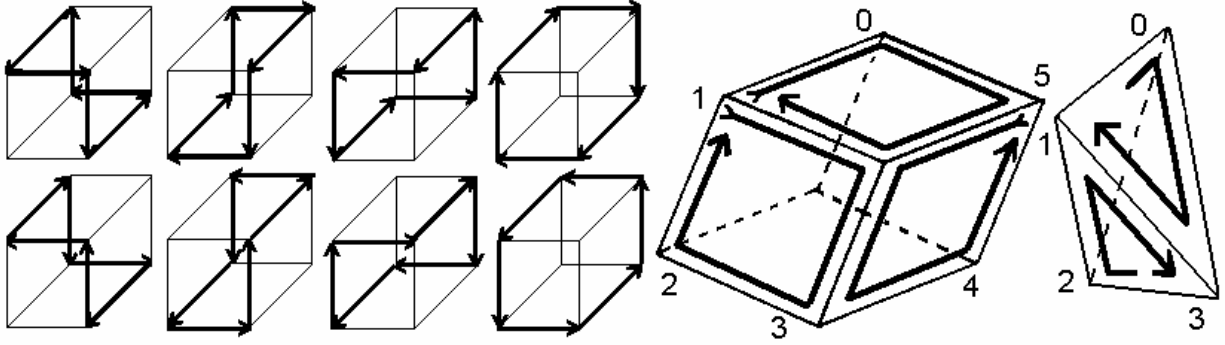

Figure 6 Part (a) shows the four possible counter-propagating (top & bottom for each case) circular permutations of the vertices of a cube representing parallel transport about each of the cubes four diagonals. These allowed paths and orientations constrict the dimensional reduction process of the entourage of associated spaces into symmetry breaking pathways according to strict rules. Ordering the vertices as shown in (b) induces an orientation on the cubes two dimensional boundary, which consists of six oriented squares by $\partial(012345)$. Note how each vertex of the cube is like the figure in 2 d). For illustration taking the simpler case of a tetrahedron (c) consisting of four oriented triangles by $\partial(0123) = (012) - (013) + (023) - (123)$. This in turn induces an orientation on the edges of the one-dimensional boundaries $\partial(012) = (01) - (02) + (12)$. Summing the dimensional boundaries cancels them in pairs $[(01) - (01) = 0]$. This is the Bianchi identity $\partial \circ \partial = 0$ described by the Regge equations for parallel transport where the boundary of a boundary is zero. Or suggesting the cube is edgeless because the 1D boundary of the 2D boundary of the 2D region is zero [54,55]. Detailed discussions are given in [54,55].

23. Developing The Line Element For Noetic Superspace

The line element of a cosmological model describes the metric or coordinate system used to establish a basis for making measurements comparing two events in the spacetime. The real parameters for the line element in standard Einstein-Minkowski space M_4 (compare (8) or for Newtonian space E_3 essentially the Pythagorean theorem) is

$$dS_0^2 = dx_1^2 + dx_2^2 + dx_3^2 - dt^2 \quad (18)$$

to which noetic superspace must make physical correspondence to be a viable theory. We begin by developing the associated eight dimensional complex space of the future-past following work initiated by Amoroso [9,10], Rauscher [50,57], Cole [49] and Hansen and Newman [58] on complex Minkowski space [59].

For $X_{\text{Re}}^j + iX_{\text{Im}}^j$ with $j = 1, 4$ and $X_{\text{Re}}^k + iX_{\text{Im}}^k$ also with $k = 1, 4$ we set up the complex relation

$$Z^{jk} = [X_{\text{Re}}^j + iX_{\text{Im}}^k], [\bar{X}_{\text{ret}}^j + \bar{X}_{\text{adv}}^k] \quad (19)$$

again with $j, k = 1, 4$ yielding the standard signature (1, 1, 1, -1). Then for the complex advanced space $+C_4$ we

have the general relation $Z_{\text{adv}}^{jk} = X_{\text{Re(adv)}}^{jk} + iX_{\text{Im(adv)}}^{jk}$, $\bar{X}_{\text{Re(adv)}}^{jk} + \bar{X}_{\text{Im(adv)}}^{jk}$ with $j = 1, 4$. For complex retarded

space $-C_4$ the relation is $Z_{\text{ret}}^{jk} = X_{\text{Re(ret)}}^{jk} + iX_{\text{Im(ret)}}^{jk}$, $\bar{X}_{\text{Re(ret)}}^{jk} + \bar{X}_{\text{Im(ret)}}^{jk}$ with $k = 1, 4$. Then the line element is

$$\Delta S^2 = \eta_{jk} dZ_{\text{adv}}^{jk} Z_{\text{ret}}^{jk} \quad (20)$$

with the further condition satisfied that $\eta_{jk} = \alpha_{jk} + i\beta_{jk}$ where

$$\alpha_{jk} (dx_-^j dx_p^k + dx_p^j dx_+^k) + \beta_{jk} (dx_-^j dx_+^k - dx_p^j dx_p^k) = 0 \quad (21)$$

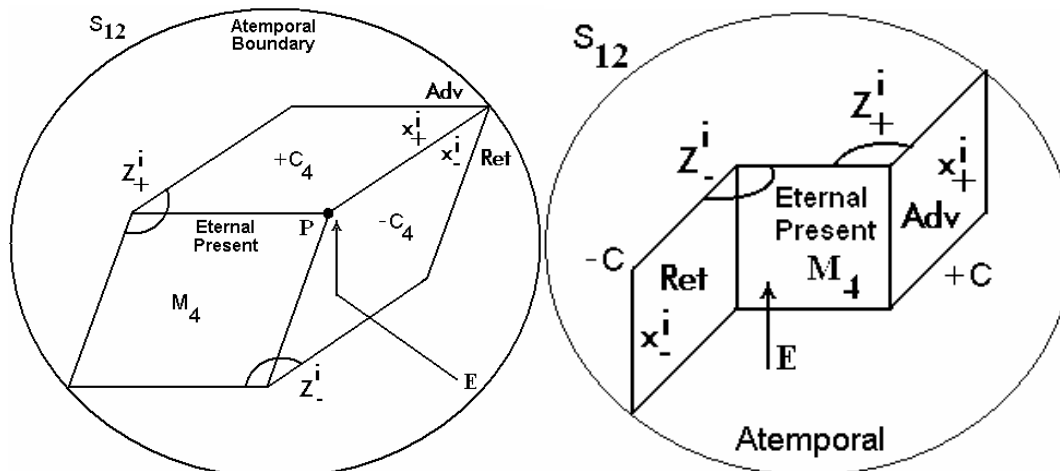

Figure 7. Two simplistic 2D representations of the three 4D spacetime packages of the periodic (11)12D noetic superspace continuous state megaverse comprising one fundamental least unit. The radius of the circle represents the variable extended Planck radius of $\hbar + N_R$ rather than just the central point E or vertex P as in a). The radius of the circles represent the extended definition of Planck's constant. The square M_4 illustrates the Euclidian based Minkowski/Riemann standing-wave eternal present with the two attached higher dimensional complex spacetime packages $\mp C$ representing the four retarded (past) and four advanced (future) dimensions respectively that put certain constraints on the description of the noetic line element in HCM cosmology.

This action directly creates boundary conditions separating the fundamental reversible aspects of microscopic natural law into the perceptual macroscopia and an additional HD physical realm not perceived by normal neurophysiology [9,52,53]. Noetic cosmology proposes that this temporal asymmetry is completely observer related and the ensuing parallel transported boundary conditions delete essentially half of the systems information cosmology. Bohr stated from the beginning that the Copenhagen interpretation did not describe biological systems; therefore a full physical description must utilize extended de Broglie/Bohm/Vigier ontological forms of quantum theory without state reduction and therefore loss of some of the systems information by uncertainty and exclusion. The big question then is what is the utility of the unobserved parameters of this noetic cosmology?

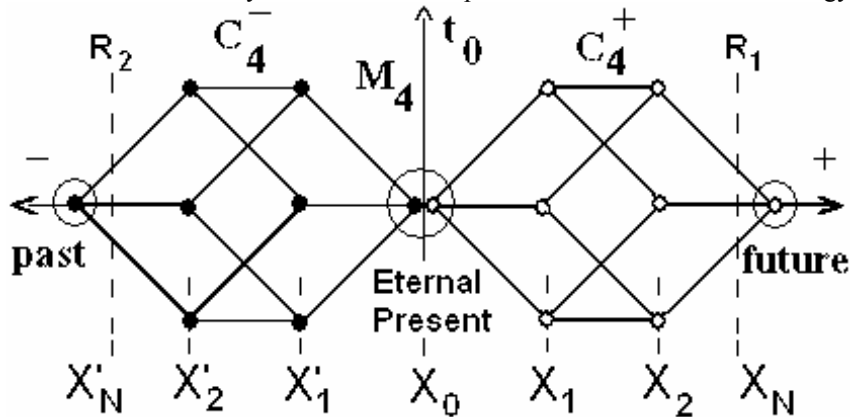

Figure 8. Exploded conceptual view of the future-past symmetry of a fundamental least unit of Noetic Superspace showing the relationship of its twelve dimensions here depicted as points. The open circled points represent future components and the solid circles represent past oriented components of a transaction. The larger circle in the center represents a suppressed view of the virtual Minkowski M_4 standing wave present comprised of the 2 obverse smaller circles at each end representing future/past components that produce it. The twelve points labeled

$\pm C_4$ symbolize an exploded conceptualization of the 12 dimensions comprising a fundamental least unit. The dimensionality and asymmetry of the complex plane is suppressed for simplicity. The 12 HD $\pm C_4$ points create and annihilate the energy dependent \hat{M}_4 eternal present (the three small circles are used to represent the simpler 3D view). The present moment is a standing wave; r_1, r_2 represent the HD boundary conditions for the standing wave (as illustrated for 1D, 2D & 3D in fig. 9.1) in terms of Cramer’s transactional model of QT [84].

Here is where the main utility of the Noetic least unit transform enters in. The complementary superluminal boosting of the ‘standing wave’ eternal present

$$D_s \rightarrow D_t \rightarrow D_E : R_U \rightarrow R_Q \rightarrow R_C \quad (22)$$

produces and maintains the perceptual macroscopic amplification of microscopic phenomena by spin-exchange annihilation and creation of the compactifying boundaries. The Noetic boosts reduce the flux of all physical fields at the boundary by absolute parallelism $\bar{\partial} \circ \partial = 0$ where the boundary of a boundary equals zero facilitating the whole cosmological process. Following Kafatos and his collaborators [60] we begin with the description of the electromagnetic field (EM). We have already stated that the continuous state compactification process in Noetic cosmology takes the place of expansion/inflation in Bigbang cosmology. Because of the antinomy conditions the rate of change of boundary conditions $\dot{R} \equiv C$ (\dot{R} is the 1st derivative or rate of change and C is the speed of light) appears the same observationally in both models. The importance of $\dot{R} \equiv C$ for universal boundary conditions which are also relevant to the velocity required for the Earth-SOLS observers mind to escape microphysical perception and become a smoothly coupled macroscopia (remember the movie theater model) for EM by

$$\bar{c} = \frac{2\bar{E} \times \bar{B}}{\bar{E}^2 + \bar{B}^2} \quad (23)$$

where, according to Wheeler [36], velocity $\bar{c} = \bar{n} \tanh \alpha$ and the numerator is the Poynting flux and the denominator the energy density. This boost equation describes reduction of the EM field to mutual parallelism; which according to the Bianchi identity (Fig 9.4 b-3D & c-4D) describes how the boundary of a boundary equals zero. Allowing half the information of the universe to cancel into the resultant standing wave covering. This is a simplistic view of the origin of the arrow of time for temporal SOLS imbedded in an eternal megaverse. The covering is piloted by the de Broglie wave-particle energy. Application of the Huygen’s principle of wave addition produces the smooth feel of reality we observe by *surfing* as it were on the face of the discrete elements of atemporal microphysics [61,62,63]!

24. Conclusions

Many new and novel trans-disciplinary concepts have been introduced. Hopefully this limited survey of such complex issues often foreign in a first exposure has given the reader the flavor of what is required to define life properly: Redefining all the standard models of science and extending them to include principles in the context of the noetic HCM arena where a rigorous formalism to define SOLS could be developed. The implications are vast. Medicine and Psychology will not be the same again; psychology can now become a physical science. Because the unified noeon field is physically real, it is therefore empirically accessible, leading to innumerable new conscious technologies that can be developed soon.

ACKNOWLEDGEMENTS

This paper is based on an unpublished talk 1st presented at The NATO Advanced Research Workshop on The Nature of Time; Geometry, Physics and Perception in Tatranská Lomnica, Slovak Republic, 21-24 May 2002.

REFERENCES

1. Varela, F.G., Maturana, H.R. & Uribe, R., 1974, Autopoiesis: The organization of living systems, its characterization and a model, *BioSystems*, 5, 187-196.
2. Jantsch, E., 1984, *The Self-Organizing Universe*, New York: Pergamon.

3. Maturana, H. R., 1970, Biology of cognition, Report BCL 9.0 Urbana: Biological Computer Laboratory, Univ. of Illinois.
4. Drăgănescu, M., 1997, On the structural phenomenological theories of consciousness, *Noetic Journal*, 1:1, 28-33.
5. von Neumann, J., 1966, The theory of self-reproducing automata, in A. Burks (ed.) Urbana: Univ. of Illinois Press.
6. Zhabotinsky, A.M., 1974, Self-oscillating Concentrations, Moscow: Nauka
7. Haldane, J.S., 1923, Mechanism, Life and Personality, New York.
8. Beckner, M.O., 1972, Mechanism in biology, in P. Edwards (ed.) *The Encyclopedia of Philosophy*, Vol. 5, pp 250-2, New York: Collier Macmillan.
9. Amoroso, R.L., 2002, Developing the cosmology of a continuous state universe, in R.L. Amoroso, G. Hunter, M. Kafatos & J-P Vigièr (eds.), *Gravitation & Cosmology: From the Hubble Radius to the Planck Scale*, Dordrecht: Kluwer Academic.
10. Amoroso R.L., 2003, Awareness: physical cosmology of the fundamental least unit, *Noetic Journal* 4:1, 1-15; Amoroso R.L., 2003, What is Consciousness, *Introducing the Cosmology of Being*, in *Romanian N. Bulz et al trans.* (in Press); Amoroso R.L., 2003, in *The Complementarity Of Mind And Body: Essay's Honoring The Centenary Of Nobelist Sir John Eccles*, R. L. Amoroso, B. J. Hiley & K. H. Pribram (eds.) In press.
11. Amoroso, R.L. 2000, The parameters of temporal correspondence in a continuous state conscious universe, in R. Buccheri & M. Saniga (eds.) *Studies in the Structure of Time: From Physics to Psycho(patho)logy*, Dordrecht Kluwer Academic.
12. Amoroso, R.L. 2003, The Fundamental Limit and Origin of Biological Systems, *Noetic Journal* 4:1; 24-32.
13. Goldberg, J.N., 1981, Spacetime, in *Encyclopedia of Physics*, R.L. Lerner & G.L. Trigg (eds.) Reading: Addison-Wesley.
14. Messiah, A., 1999, *Quantum Mechanics*, Mineola: Dover.
15. Prigogine, I., 1973, Irreversibility as a symmetry breaking factor, *Nature*, 248: 67-71.
16. Prigogine, I., Nicolis, G. & Babloyantz, A., 1972, Thermodynamics of evolution, *Physics Today*, 25: 23-28 & 38-44.
17. Chalmers, D.J., 2002, The puzzle of conscious experience, *Scientific American Special*, 12:1, 90-100.
18. Searle, J. R., 2002, Consciousness, *Review Roumaine de Philosophie*, Tome 46:1-2, pp.87-108.
19. Prusiner, S.B. 1982, *Science*, 216,p. 136-144.
20. Prusiner, S.B. 1998, *Proc Nat. Acad. Sci, USA*, 95, p. 13363-13383.
21. Amoroso, R.L. 2004, The primary mechanism initiating protein conformation in prion propagation, preprint.
22. Gould, L.I., 1995, Quantum dynamics and neural dynamics: Analogies between the formalisms of Bohm and Pribram, in J. King & K.H. Pribram, (eds.) *Scale in Conscious Experience: Is the Brain Too Important to be Left to Specialists to Study?* 339-348, Mahwah: Lawrence Erlbaum.
23. Pribram, K.H., 1991, *Brain and Perception: Holonomy and Structure in Figural Processing*, Mahwah: Lawrence Erlbaum; Eccles, J.C., 1986, Do mental events cause neural events analogously to the probability fields of quantum mechanics?, *Proc. Royal Soc. London B227*, pp. 411-428.
24. Jibu, M. & K. Yasue, 1995, *Quantum Brain Dynamics and Consciousness*, Amsterdam: John Benjamins.
25. Brillouin, L., 1949, Life, thermodynamics and cybernetics, *American Scientist*, 37: 554-568.
26. Chalmers, D. 1996, *The Conscious Mind*, Oxford: Oxford University Press.
27. Schrodinger, E., 1945, *What is Life?* London: Cambridge University Press. Bohr, N., 1961, *Atomic Theory and the Description of Nature*, Cambridge: Cambridge University Press.
28. Amoroso, R.L., 2002, The Physical Basis of Consciousness: A Fundamental Formalism, Part 1 Noesis, XXVI, *Romanian Academy*; Amoroso, R.L, 2000, Derivation of the fundamental equation of consciousness, Part I, Boundary conditions, *Noetic Journal* 3:1, pp. 91-99.
29. Amoroso, R.L, Consciousness, a radical definition: Substance dualism solves the hard problem, In Amoroso, R.L., Antunes, R., Coelho, C., Farias, M., Leite, A., & Soares, P. (eds.) *Science and the Primacy of Consciousness*, 2000, Orinda: The Noetic Press; Amoroso, R.L, An introduction to noetic field theory: The quantization of mind, *The Noetic Journal* 2:1, pp. 28-37 (1999). Amoroso, R.L, 2000, Derivation of the fundamental equation of consciousness, Part I, Boundary conditions, *Noetic Journal* 3:1, pp. 91-99.
30. Wegner, P., 1998, Interactive foundations of computing, *Theoretical Computer Science*, 192, 315-351.
31. Schutz, B. 1999, *Geometrical Methods of Mathematical Physics*, Cambridge: Cambridge University Press.
32. Fröhlich, H., 1968, Long-range coherence and energy storage in biological systems, *Int. J. Quantum Chem.* 2:641-649.
33. Hagelin, J.S., 1988, Is consciousness the unified field? A field theorist's perspective. Preprint.

34. Ciubotariu, C & Ciubotariu, C. , 2002, A chaotic-stochastic model of an atom, in R.L. Amoroso, G. Hunter, M. Kafatos & J-P Vigiér (eds.), *Gravitation and Cosmology: From the Hubble Radius to the Planck Scale*, Dordrecht: Kluwer Academic.
35. Argyris, J. & Ciubotariu, C., 1999, A new physical effect modeled by an Ikeda map depending on a monotonically time-varying parameter, *Int. J. Bif. Chaos*, 9:1111-1120.
36. Wheeler, J.A. 1977, Gravitational and Electromagnetic wave flux compared and contrasted, *Phys. Rev. D*, 16:12, 3384-3389.
37. Loudon, R. 1994, *The Quantum Theory of Light*, Oxford: Clarendon Press.
38. Prusiner, S.B., 2002, Research Summary, www.ucsf.edu/neurosc/faculty/neuro-prusiner.html.
39. Huang, Z., Gabriel, J-M, Baldwin, M.A., Fletterick, R.J., Prusiner, S.B., & Cohen, F.E., 1994, Proposed three-dimensional structure for the cellular prion protein, *Proc. Nat. Acad. Sci, USA*, 91, pp. 7139-7143.
40. Kurschner, C. & Morgan, J.I. 1996, *Mol. Brain Res.* 37, pp. 249-258.
41. Wheeler, J.A., & Feynman, R., 1945, *Rev. Mod. Physics*, 17, 157; Chu, S-Y, 1993, *Physical Rev. L.* , 71, 2847.
42. Witten, E., 1981, Search for a realistic Kaluza-Klein theory, *Nuclear Physics B*186, 412-428.
43. Sen, R.N., 1999, Why is the Euclidian line the real line?, *Found. Physics*, 12:4,328-345.
44. Hocking, & Young, 1988, *Topology*, New York: Dover.
45. Barrow, J.D. & Tipler, F.J., 1988, *The Anthropic Principle*, Oxford: Oxford Univ. Press.
46. Vigiér, J-P & Amoroso, R.L. Can one unify gravity and electromagnetic fields? in R.L. Amoroso, G. Hunter, S. Jeffers & M. Kafatos, (eds.), *Gravitation & Cosmology: From the Hubble Radius to the Planck Scale*, 2002, Dordrecht: Kluwer Academic.
47. Overduin, J.M. & Wesson, P.S., 1997, Kaluza-Klein gravity, *Physics Reports*, 283, pp. 303-378.
48. Dirac, P.A.M., 1952, *Nature (London)*, 169, 702; Petroni, C. & Vigiér, J-P, 1983, *Found. Phys.* 13, 253; Vigiér, J-P, 1980, *Lett. Nuovo Cim.* 29, 467.
49. Cole, E.A.B., 1977, *Il Nuovo Cimento*, 40:2, 171-180.
50. Rauscher, E., 2002, Non-Abelian gauge groups for real & complex Maxwell's equations, in R.L. Amoroso, G. Hunter, S. Jeffers & M. Kafatos, (eds.), *Gravitation & Cosmology: From the Hubble Radius to the Planck Scale*, Dordrecht: Kluwer.
51. Burns, J.E. (1998) Entropy and vacuum radiation, *Found. Phys.* 28 (7), 1191-1207; Burns, J.E. (2002), Vacuum radiation, entropy and the arrow of time, in R.L. Amoroso, G. Hunter, S. Jeffers & M. Kafatos, (eds.), *Gravitation & Cosmology: From the Hubble Radius to the Planck Scale*, 2002, Dordrecht: Kluwer Academic.
52. Zeh, H.-D. (1989) *The Physical Basis of the Direction of Time*, Springer-Verlag, New York; Franck, G. 2000, Time & presence, in *Science & The Primacy of Consciousness*, R.L. Amoroso et al, (eds.) Orinda: Noetic Press.
53. Wheeler, J.A. 1955, Geons, *Physical Review*, 97:2, 511-536.
54. Misner, C.W., Thorne, K. & Wheeler, J.A. 1973, *Gravitation*, San Francisco: Freeman.
55. Miller, W.A. 1986, *Found. Phys.* 16:2, 143-169.
56. Gondran, M. 2002, A trajectory model for a particle in the Schrodinger approximation, preprint.
57. Rauscher, E. A. , 1983, *Electromagnetic Phenomena in Complex Geometries and Nonlinear Phenomena, Non – Hertzian Waves and Magnetic Monopoles*, Millbrae: Tesla Books.
58. Hansen, R.O. & Newman, E.T., 1975, *General Relativity and Gravitation* 6:21.
59. Stevens, H.H, 1989, Size of a least unit, in M. Kafatos (ed.) *Bell's Theorem, Quantum Theory and Conceptions of the Universe*, Dordrecht: Kluwer Academic.
60. Kafatos, M. Roy, S. & Amoroso, R. 2000, Scaling in Cosmology & the Arrow of Time, in Buccheri, di Gesu & Saniga, (eds.) *Studies on Time*, Dordrecht: Kluwer Academic.
61. Ueda, Y. & Akamatsu, N., 1981, Chaotically transitional phenomena in the forced negative-resistance oscillator, *IEEE Transactions on Circuits & Systems*, Vol. CAS-28, No. 3, 217-224.
62. Lichtenberg, A.J. & Liebrman, M.A., 1983, *Regular And Stochastic Motion*, Berlin: Springer.
63. Humieres, D., Beasley, M.R., Huberman, B.A. & Libchaber, A., 1982, Chaotic states and routes to chaos in the forced pendulum, *Physical Rev A*, 26:6, 3483-34.
64. Villarreal, L.P., 2004, Are viruses alive? *Scientific American*, 291:6, pp. 100-105.
65. Amoroso, R.L., 2005, The Fundamental Limit and Origin of Complexity in Biological Systems: A New Model for the Origin of Life, in D. Dubois, (ed.) *Proceedings of CASYS04*, Liege, Belgium, AIP Proceedings.
66. Prusiner, S.B. 1982, *Science*, 216,p. 136-144.
68. Prusiner, S.B. 1998, *Proc Nat. Acad. Sci, USA*, 95, p. 13363-13383.
69. Dubois, D.M., 1998, Computing anticipatory systems with incursion and hyperincursion, in D.M. Dubois (ed.), *Computing Anticipatory Systems: CASYS –First Intl Conference*, Am Inst of Physics: AIP Conf. Proceedings.

70. Dubois, D.M., 2001, Theory of incursive synchronization and application to the anticipation of delayed linear and nonlinear systems, in D.M. Dubois (ed.), *Computing Anticipatory Systems: CASYS 2001 –Fifth Intl Conference*, Am Inst of Physics: AIP Conf. Proceedings 627, pp. 182-195.
71. Amoroso, R.L., 1996, The production of Fröhlich and Bose-Einstein coherent states in in vitro paracrystalline oligomers using phase control laser interferometry, *Bioelectrochemistry & Bioenergetics*, 41:1, pp.39-42.
72. Amoroso, R.L., Utility of Dirac interferometry for empirical isolation of the noetic field, in preparation.
73. Smolin, L. 2000, The strong and weak holographic principles, arXiv:hep-th/0003056 v1; Suskind, L. 1994, The world as a hologram, arXiv:hep-th/9409089 v2.
74. Grotz, K., & KlapdorH.V., 1990, *The Weak Interaction in Nuclear, Particle and Astrophysics*, Bristol: Adam Hilger.
75. Duff, M.J., Nilsson, B.E.W & Pope, C.N., 1983, *Proc 4th Workshop Grand Unification*, Philadelphia, H.A. Welden, P. Langacker & P.J. Steinhardt, p. 341, Stuttgart: Birkhäuser.
76. Vigier, J-P., 1997, Possible consequences of an extended charged particle model in electromagnetic theory, *Physics Letters A*, 235:5, pp. 419-31.
77. Witten, E., 1996, Reflections on the fate of spacetime, *Physics Today* (April), pp. 24-30.78. Adapted from a statement made by Sir Arthur Eddington.
79. Peebles, P.J.E. 1993, *Principles of Physical Cosmology*, Princeton: Princeton University Press.
80. Amoroso, R.L, & Vigier, J-P , 2002, The origin of cosmological redshift and CMBR as absorption/emission equilibrium in cavity-QED blackbody dynamics of the Dirac vacuum, In Amoroso, R.L., Hunter, G., Kafatos, M., Vigier, J-P. (Eds.) *Gravitation & Cosmology: From the Hubble Radius to the Planck Scale*, 2002, Dordrecht: Kluwer.
81. Vigier, J-P., 1954, Model of the causal interpretation of quantum theory in terms of a fluid with irregular fluctuations, *Physical Review*, 96:1, pp. 208-17.
82. Penrose, R. 1989, *The Emperor’s New Mind*, Oxford: Oxford Univ Press.
83. Hofstadter, D.R., 1979, *Gödel, Escher, Bach: An Eternal Golden Braid*, New York: Vintage Books.
84. Amoroso, R.L., 2005, *Universal Quantum Computing: Anticipatory Parameters Predicting Bulk Implementation: Journal of CASYS05*, Liege Belgium, in press.
85. Cramer, J, 1986, The Transactional Interpretation of Quantum Mechanics, *Rev. Mod. Phys* 58, 647-687.
86. Amoroso, R.L. , *Transcendent revelation received 1995*, Oakland, CA
87. Sklar, L. 1995, *Philosophy and Spacetime Physics*, Berkeley: Univ. of California Press; Reichenbach, H. 1957, *Philosophy of Space and Time*, New York: Dover.
88. Holland, P.R. 1993, *The Quantum Theory of Motion*, Cambridge: Cambridge Univ. Press.
89. Amoroso, R.L. and Martin, B. Modeling the Heisenberg matrix: Quantum coherence and thought at the holoscape manifold and deeper complementarity. In J. King & K.H. Pribram, Eds. *Scale in Conscious Experience: Is the Brain too Important to be Left to Biologists to Study?* (1995) Lawrence Earlbaum, Mahwah.
90. Dirac, P.A.M., 1951, *Nature*, 168, 906
91. Lehnert, B., 2002, New developments in electromagnetic field theory, In Amoroso, R.L., Hunter, G., Kafatos, M., Vigier, J-P. (Eds.) *Gravitation & Cosmology: From the Hubble Radius to the Planck Scale*, pp. 125-146, Dordrecht: Kluwer.
92. Amoroso, R.L. , 2006, Experimental design for the Noetic-Dirac interferometer, in preparation.
93. Vigier, J-P., 1983, Dirac’s aether in relativistic quantum mechanics, *Foundations of Physics*, 13:2, pp. 253-285.
94. Stapp, H.P., 2000, Why classical mechanics cannot naturally accommodate consciousness but quantum mechanics can, in R.L. Amoroso et al, *Science and the Primacy of Consciousness*, Orinda, Noetic Press.
95. Amoroso, R.L., 2000, Call for a model of deep ontology – A commentary on Stapp: “Why classical mechanics cannot naturally accommodate consciousness but quantum mechanics can”, in R.L. Amoroso et al, *Science and the Primacy of Consciousness*, Orinda: The Noetic Press.

